



**PERFORMANCE DATA SHEET  
NEMA PREMIUM NR CAN NEMA 12 - 12**

Catalogue #: MQP-41

HP	kW	Voltage	S.F. @ 60Hz	EFF.	P.F.	Frame	Design	L.R. Amps
20	14,92	230/460	1,25	91,0%	0,87	256T	B	145

60 Hz								Code	F.L. RPM
208	230	416	460	480	575	600			
/	47	/	23,50	/	/			G	3540

50 Hz								
FLA			S.F. @ 50Hz	Efficiency	Power Factor	Code	F.L. RPM	
190	380	415						
57,0	28,5		1,00	89,5%	0,890	E	2920	

Wgt. Lbs	PH	Duty	Insul. Class	Amb.	Elevation	Temp. Rise° C
315	3	Cont.	F	40°C	1000M (3,300 Ft)	53

% Efficiency		% Power Factor		Torque		Winding Resist. Ω	Safe Cold Start (Secs)
Full Load:	91,0%	Full Load:	0,87	Full Load Ft/Lbs	29,7		
3/4 Load:	91,0%	3/4 Load:	0,85	Locked Rotor %	150		
1/2 Load:	90,0%	1/2 Load:	0,79	Break Down %	250	0,42	20

Rotor Inertia Wk2 Lb-Ft2	Max Load Inertia Wk2 Lb-Ft2	Shaft Material	Frame Material	DE Bracket Type	ODE Bracket Type	Enclosure	NEMA Rating	Lead Wire Size
1,19	31	1045	Cast Iron	Cast Iron	Cast Iron	TEFC	IP55	12AWG

Ball Bearings		Grease	Mount Type	Orientation	Paint	Sound Pressure @ 3FT	Sound Power
DE	ODE						
6309	6309	Mobil PolyrexEm	Rigid	Horizontal	RAL6022	84	94

Inverter Duty, Motor meets MG1 parts 31.4.4.2	VFD SF	Constant Torque Range	Variable Torque Range	Constant HP RPM
	1,00	10:1	20:1	5400

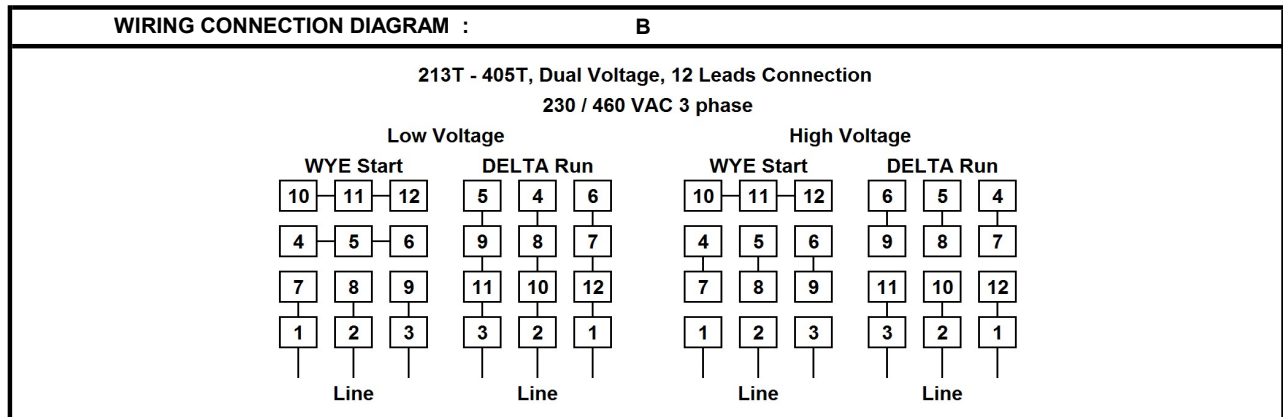

Date: 2023-12-13  
 Customer: \_\_\_\_\_  
 Contact: \_\_\_\_\_  
 Submittee: J.C. Lavallée

Catalogue #: **MQP-41**

NEMA PREMIUM NR CAN NEMA 12 - 12										
HP	VAC	RPM	Enclosure	Frame	Frequency	Design	Poles	LR Code Letter	Insulation Class	Temp. Rise °C
20	460	3540	TEFC	256T	60 Hz	B	2	G	F	53
	0Hz	6Hz	15Hz	30Hz	45Hz	60 Hz	75Hz	90Hz	105Hz	120Hz
Amps	23,5	23,5	23,5	23,5	23,5	23,5	23,5	23,5	23,5	23,5
RPM	0	354	885	1770	2655	3540	4425	5310	6195	7080
Torq ft.lb	23,74	23,74	29,67	29,67	29,67	29,67	23,74	19,78	16,96	14,84
Peak Tq ft.lb	33,38	66,76	66,76	66,76	66,76	66,76	53,41	44,51	38,15	33,38
HP	0	1,6	5,0	10,0	15,0	20,0	20,0	20,0	20,0	20,0
	Locked Rotor	Pull-Up	Breakdown	Rated Load	Idle	Duty	S. F.	Ambient	Elevation	dBA @ 1M
Speed (RPM)	0,0	1512	2880	3540	3600	Continuous	1,25	40°C	3,300 ft	84
Current (Amps)	145,0	123,3	86,3	23,5	8,9	VFD Rating: Meets MG1 parts 31.4.4.2				
Torque (ft-lbs)	44,5	33,4	74,2	29,7	0,0	C.T.	10:1	V.T.	20:1	VFD SF 1.00

Motor Speed Data

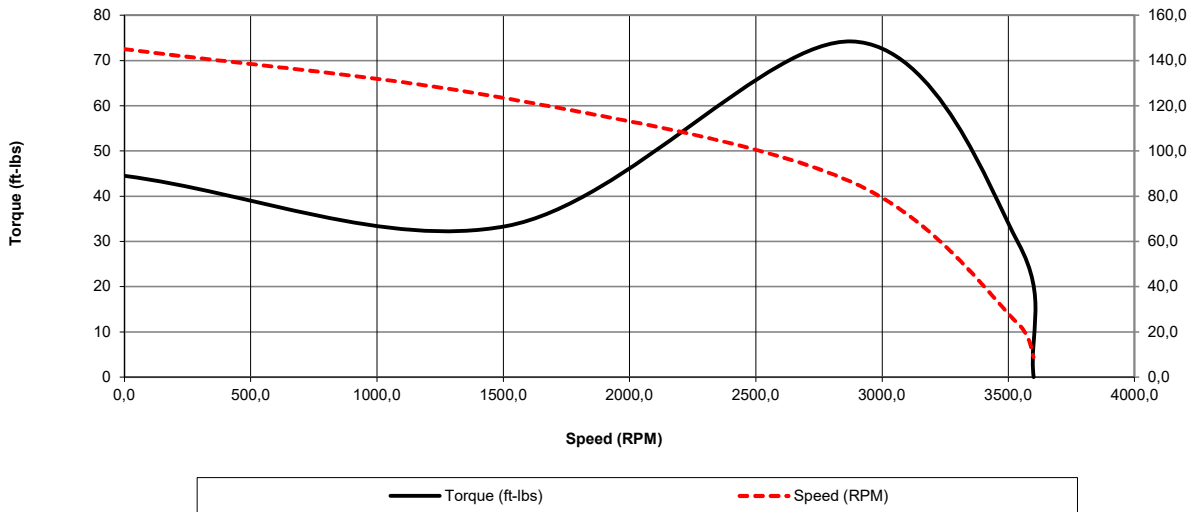

Motor Torque Capability vs RPM

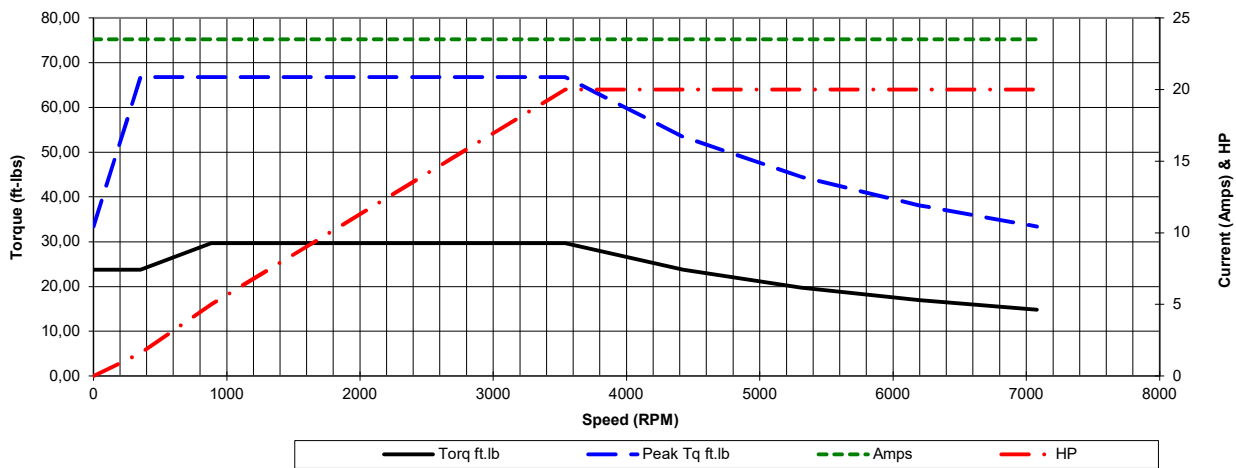



Date: 2023-12-13  
 Customer: \_\_\_\_\_  
 Contact: \_\_\_\_\_  
 Submittee: J.C. Lavallée

Catalogue #: **MQP-41**

NEMA PREMIUM NR CAN NEMA 12 - 12										
HP	VAC	RPM	Enclosure	Frame	Frequency	Design	Poles	LR Code Letter	Insulation Class	Temp. Rise °C
20	460	3540	TEFC	256T	60 Hz	B	2	G	F	53
Load %	0%	25%	50%	75%	100%	125%	150%			
Amps	8,93	10,03	13,91	18,35	23,50	29,65	35,80			
Torq ft/lbs	0	7,32	14,71	22,16	29,67	37,25	44,89			
RPM	0	3585	3570	3555	3540	3525	3510			
Eff	0	82,72	90,00	91,00	91,00	89,57	89,22			
PF	0	56,4	79	85	87	88,131	87,957			
	Locked Rotor	Pull-Up	Breakdown	Rated Load	Idle	Duty	S. F.	Ambient	Elevation	dBa @ 1M
Speed (RPM)	0	1512	2880	3540	3600	Continuous	1,25	40°C	3,300 ft	84
Current (Amps)	145	123,3	86,3	23,5	8,93	VFD Rating: Meets MG1 parts 31.4.4.2				
Torque (ft-lbs)	44,51	33,38	74,18	29,67	0,0	C.T.	10:1	V.T.	20:1	VFD SF 1.00

